

## TROUBLESHOOTING FREQUENTLY ASKED QUESTIONS

### TROUBLESHOOTING

TROUBLE	PROBABLE CAUSE	SOLUTION
• Unit does not turn on.	<ul style="list-style-type: none"> <li>☛ Not plugged in.</li> <li>☛ Outlet not functioning.</li> </ul>	<ul style="list-style-type: none"> <li>✓ Plug in unit.</li> <li>✓ Have outlet replaced by a licensed electrician.</li> </ul>
• Mist output insufficient or none.	<ul style="list-style-type: none"> <li>☛ Speed setting is on LO</li> <li>☛ The filter has not absorbed water.</li> <li>☛ Filter support cap not positioned correctly.</li> </ul>	<ul style="list-style-type: none"> <li>✓ Operate on HI setting.</li> <li>✓ Wait 30 minutes for filter to absorb water.</li> <li>✓ Support cap should rest on top of filter.</li> </ul>
• Filter turns brown.	<ul style="list-style-type: none"> <li>☛ The filter has absorbed minerals.</li> </ul>	<ul style="list-style-type: none"> <li>✓ Follow the Filter Washing Procedure to wash your filter (HWF75P). If damaged or lost, order replacement filter by calling 1-800-253-2764, or visiting <a href="http://www.bionaire.com">www.bionaire.com</a>.</li> </ul>

### FREQUENTLY ASKED QUESTIONS

Question	Answer
• What are the variables that affect run time?	<p>The estimated run time for this humidifier is based on average room conditions. The actual run time of your humidifier is dependent on numerous variables such as:</p> <ul style="list-style-type: none"> <li>✓ Air exchange in the room where the humidifier is placed.</li> <li>✓ Room construction of the room where the humidifier is placed.</li> <li>✓ Temperature of the room where the humidifier is placed.</li> <li>✓ Humidity levels in the room where the humidifier is placed.</li> <li>✓ Movement of occupants and the opening and closing of doors in the room where the humidifier is placed.</li> <li>✓ Home furnishings in the room where the humidifier is placed.</li> </ul>
• How do I remove film on water tank?	<ul style="list-style-type: none"> <li>✓ See Daily Maintenance instructions. Regular cleaning is recommended.</li> </ul>
• How can I extend the run time?	<ul style="list-style-type: none"> <li>✓ Run your unit on the lowest setting.</li> <li>✓ If your unit has electronics, set it to your desired humidity level. The unit will turn on and off, which will extend the run time.</li> <li>✓ Fill the tank all the way full, place it on the base, let the water empty into the base until it stops bubbling, then refill the tank fully again. This ensures maximum water capacity and will extend run time.</li> </ul>

## CLEANING / MAINTENANCE

### STORAGE INSTRUCTIONS

If your humidifier will not be in use for two days or more, follow these instructions.

1. Clean, rinse and thoroughly dry the humidifier as directed in weekly maintenance. DO NOT leave any water inside the base or tray.
2. Remove the tank cap. Do not store with the tank cap in place.
3. Place the humidifier in the original carton and store in a cool, dry place.
4. Always clean the humidifier before the next season begins.
5. Wash your permanent filter or order replacement filter for next year's use.

### REPLACEMENT ACCESSORIES

To order the replacement accessories you can do any of the following:

- Visit your local retailer
- Go to [www.bionaire.com](http://www.bionaire.com)
- Call Consumer Service at 1-800-253-2764

If you have any questions regarding your product or would like to learn more about other Bionaire® products, please contact our Consumer Service Department at 1-800-253-2764 or visit our website at [www.bionaire.com](http://www.bionaire.com).

## WARRANTY INFORMATION

### 1 YEAR LIMITED WARRANTY

Sunbeam Products, Inc. doing business as Jarden Consumer Solutions or if in Canada, Sunbeam Corporation (Canada) Limited doing business as Jarden Consumer Solutions (collectively "JCS") warrants that for a period of one year from the date of purchase, this product will be free from defects in material and workmanship. JCS, at its option, will repair or replace this product or any component of the product found to be defective during the warranty period. Replacement will be made with a new or remanufactured product or component. If the product is no longer available, replacement may be made with a similar product of equal or greater value. This is your exclusive warranty. Do NOT attempt to repair or adjust any electrical or mechanical functions on this product. Doing so will void this warranty. This warranty is valid for the original retail purchaser from the date of initial retail purchase and is not transferable. Keep the original sales receipt. Proof of purchase is required to obtain warranty performance. JCS dealers, service centers, or retail stores selling JCS products do not have the right to alter, modify or any way change the terms and conditions of this warranty.

This warranty does not cover normal wear of parts or damage resulting from any of the following: negligent use or misuse of the product, use on improper voltage or current, use contrary to the operating instructions, disassembly, repair or alteration by anyone other than JCS or an authorized JCS service center. Further, the warranty does not cover: Acts of God, such as fire, flood, hurricanes and tornadoes.

### What are the limits on JCS's Liability?

JCS shall not be liable for any incidental or consequential damages caused by the breach of any express, implied or statutory warranty or condition.

Except to the extent prohibited by applicable law, any implied warranty or condition of merchantability or fitness for a particular purpose is limited in duration to the duration of the above warranty.

JCS disclaims all other warranties, conditions or representations, express, implied, statutory or otherwise.

JCS shall not be liable for any damages of any kind resulting from the purchase, use or misuse of, or inability to use the product including incidental, special, consequential or similar damages or loss of profits, or for any breach of contract, fundamental or otherwise, or for any claim brought against purchaser by any other party.

Some provinces, states or jurisdictions do not allow the exclusion or limitation of incidental or consequential damages or limitations on how long an implied warranty lasts, so the above limitations or exclusion may not apply to you.

This warranty gives you specific legal rights, and you may also have other rights that vary from province to province, state to state or jurisdiction to jurisdiction.

### How to Obtain Warranty Service

#### In the U.S.A.

If you have any question regarding this warranty or would like to obtain warranty service, please call 1-800-253-2764 and a convenient service center address will be provided to you.

#### In Canada

If you have any question regarding this warranty or would like to obtain warranty service, please call 1-800-253-2764 and a convenient service center address will be provided to you.

In the U.S.A., this warranty is offered by Sunbeam Products, Inc. doing business as Jarden Consumer Solutions located in Boca Raton, Florida 33431. In Canada, this warranty is offered by Sunbeam Corporation (Canada) Limited doing business as Jarden Consumer Solutions, located at 20 B Hereford Street, Brampton, Ontario L6Y 0M1. If you have any other problem or claim in connection with this product, please write our Consumer Service Department. **PLEASE DO NOT RETURN THIS PRODUCT TO ANY OF THESE ADDRESSES OR TO THE PLACE OF PURCHASE.**

© 2012 Sunbeam Products, Inc. doing business as Jarden Consumer Solutions. All Rights Reserved.  
Distributed by Sunbeam Products, Inc. doing business as Jarden Consumer Solutions, Boca Raton, Florida 33431.

157608  
GCDS-B1026583-AB

BCM3855C-U12EM1

Printed In China

# BIONAIRE®

pure indoor living



## COOL MIST HUMIDIFIER

FILTER# : HWF75P  
FILTER TYPE : Permanent

MODEL: BCM3855C

## Instruction Leaflet

Read instructions before operating. Retain for future reference.

Questions? Comments? Call 1-800-253-2764 in North America.

## PLEASE READ AND SAVE THESE IMPORTANT SAFETY INSTRUCTIONS

When using electrical appliances, basic safety precautions should always be followed to reduce the risk of fire, electric shock, and injury to persons, including the following:

1. Read all instructions before using the appliance.
2. To avoid fire or shock hazard, plug the appliance directly into a 120V AC electrical outlet.
3. Keep the cord out of heavy traffic areas. To avoid fire hazard, NEVER put the cord under rugs or near heat registers.
4. DO NOT place humidifier near heat sources such as stoves, radiators, and heaters. DO locate your humidifier on an inside wall near an electrical outlet. The humidifier should be at least 4 inches (10 cm) away from the wall for best results.
5. NEVER place humidifier in an area where it is accessible to children. NEVER use humidifier in a closed room, particularly where a child may be sleeping, resting, or playing (a closed room may result in excessive humidity).
6. **WARNING:** Do not attempt to refill humidifier without first unplugging the unit from its electrical outlet. Failure to heed this warning may cause personal injury. Be sure to unplug the unit by pulling on the plug and not the cord.
7. Never place anything over moisture outlet when the unit is running.
8. NEVER drop or insert any object into any openings.
9. DO NOT operate any appliance with a damaged cord or plug, after the appliance malfunctions, or if it has been dropped or damaged in any manner. Return appliance to manufacturer for examination, electrical or mechanical adjustment, or repair.
10. Use appliance only for intended household use as described in this manual. Any other use not recommended by the manufacturer may cause fire, electric shock, or injury to persons. The use of attachments not recommended or sold by the manufacturer may cause hazards.
11. DO NOT use outdoors.
12. Always place humidifier on a firm, flat, level surface. A waterproof mat or pad is recommended for use under the humidifier. NEVER place it on a rug or carpet, or on a finished floor that may be damaged by exposure to water or moisture.
13. DO NOT allow the Moisture Outlet to directly face the wall. Moisture could cause damage, particularly to wallpaper.
14. Humidifier should be unplugged when not in use.
15. NEVER tilt, move, or attempt to empty unit while it is operating. Shut off and unplug before removing the water tank and moving the unit.
16. This humidifier requires daily and weekly maintenance to operate appropriately. Refer to the instructions in the CLEANING/MAINTENANCE section and use only cleaners and additives recommended.
17. NEVER use detergents, gasoline, glass cleaner, furniture polish, paint thinner, or other household solvents to clean any part of the humidifier.
18. Excessive humidity in a room can cause water condensation on windows and some furniture. If this happens, turn the humidifier OFF.
19. Do not use humidifier in an area where humidity level is in excess of 50%. Use a hygrometer, available at your local retailer or through the manufacturer, to measure the humidity.
20. DO NOT attempt to repair or adjust any electrical or mechanical functions on this unit. Doing so will void your warranty. The inside of the unit contains no user serviceable parts. All servicing should be performed by qualified personnel only.
21. Never place housing under water flow or immerse in liquids.
22. Do not plug in the cord with wet hands: electric shock could result.
23. Do not pour water in any openings other than the water tank.
24. To prevent damage to surfaces, do not place humidifier under overhanging surfaces.
25. NEVER operate unit without water in the tank.

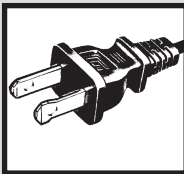

**THIS APPLIANCE HAS A POLARIZED PLUG (one blade is wider than the other). To reduce the risk of electric shock, this plug is intended to fit in a polarized outlet only one way. If the plug does not fit fully in the outlet, reverse the plug. If it still does not fit, contact a qualified electrician to install the proper outlet.**

**DO NOT ATTEMPT TO MODIFY THIS PLUG OR DEFEAT THIS SAFETY FEATURE IN ANY WAY.**

## FEATURES - OPERATIONS

26. Do not move unit after it has been used until unit cools completely.
27. Use both hands when carrying full tank of water.

## PLEASE READ AND SAVE THESE IMPORTANT SAFETY INSTRUCTIONS

### CONSUMER SAFETY INFORMATION

**NOTE:** This is an electrical appliance and requires attention when in use.

**NOTE:** If moisture forms on the walls or windows of the room, turn off the humidifier. The room already has plenty of humidity and additional moisture may cause damage.

**NOTE:** DO NOT block air inlet or outlet.

### Cord and Plug Installation Safety Instructions:

The length of cord used on this appliance was selected to reduce the hazards of becoming tangled in, or tripping over a longer cord. If a longer cord is necessary an approved extension cord may be used. The electrical rating of the extension cord must be equal to or greater than the rating of the humidifier (refer to the rating information placed on the humidifier). Care must be taken to arrange the extension cord so that it will not drape over the countertop or tabletop where it can be pulled on by children or accidentally tripped over.

### HOW COOL MIST WORKS

Your Bionaire® Cool Mist humidifier draws dry air through the air intake grill area. This air is then passed through a moisture-laden wick filter (permanent), which retains the minerals and deposits in the water. The resulting moist air is directed back into the room from the top air grill.

**NOTE:** This humidification system provides a cool, invisible moisture output. It is normal not to see the mist.

**NOTE:** A humidity level below 20% can be unhealthy and uncomfortable. The recommended humidity level is between 40%-50%.

### PRE-OPERATING INSTRUCTIONS

1. Be sure the humidifier is switched to OFF and the unit is disconnected from the electrical outlet.
2. Choose a location out of reach of children. DO NOT place the humidifier on a finished floor or near furniture which can be damaged by moisture or water.
3. To ensure proper performance, make sure filter is fully seated in water tray. Make sure filter support cap is also in place (see Figure 1).

### FILLING THE WATER TANKS

1. Remove the two tanks from the back of the humidifier and bring each tank to the faucet. Turn the tank upside down and twist off the large tank cap by turning counter-clockwise. Fill each tank with cool, fresh tap water. **Replace the cap on each tank FIRMLY.**

**NOTE:** Adding a water softening agent like Water Treatment (Model S1705) to the water will soften mineral deposits and prevent lime and scale build-up. It will also help prolong the life of the wick filter and make cleaning easier.

2. When full, carry each tank by holding the handle on top of each tank to the humidifier and place back to the unit (use both hands when carrying each tank). Each tank holds 1.45 Gallons of water. When the water stops emptying, remove the tanks and refill each again. Replace the tanks onto the humidifier housing. The WATER LIMITING feature on the tank cap will prevent the tanks from overflowing. **YOU NOW HAVE 1.45 GALLONS OF WATER IN EACH TANK FOR A TOTAL OF 2.9 GALLONS OF WATER.**

3. Plug the power cord into a 120V AC electrical outlet.

### OPERATING INSTRUCTIONS

With the filter installed correctly (plastic filter support cap placed on top of the filter - see Figure 1), front door closed, the tanks filled and the plug correctly inserted in the outlet, you are now ready to operate the humidifier.

**NOTE:** The humidifier produces clean, cool, INVISIBLE moisture. It is normal not to see the moisture.

## FEATURES - OPERATIONS

1. Press the Power Button (⏻) to turn the humidifier on, the humidifier will run at High setting and the "Hi/Express Mode" indicator light will illuminate.
2. Allow up to 30 minutes for the filter to fully absorb water and the unit to produce the maximum moisture output.
3. If you want to switch to the Low setting, press the Speed Button (⏸) and the "Lo/Quiet Mode" indicator light will illuminate.
4. To shut the humidifier off at any setting, press the Power Button (⏻) until all indicator lights go off.

### Digital Humidistat Control

Your humidifier is equipped with a digital humidistat that allows you to set your humidifier to your desired comfort level by pressing the +/- buttons to adjust the humidity level ranging from 45% to Stay On setting. The corresponding Humidity Indicator will illuminate once selected. When the room humidity level rises above the set humidity, the humidifier will stop running. When the room humidity level drops below the set humidity, the humidifier will turn on automatically to maintain the preset humidity level.

**NOTE:** When the water tank is empty, and the base is almost empty, you need to refill the tank. The fan will continue to run to help dry the humidifier. Shut off and unplug the unit. Please follow the Daily Cleaning Instructions. Refill the tank as directed in Filling the Water Tanks Instructions.

**NOTE:** If moisture forms on the walls or windows, turn off the humidifier.

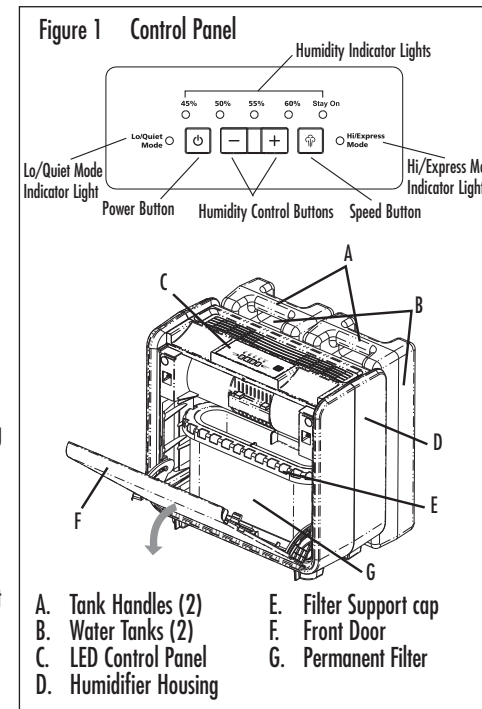

### CLEANING THE PERMANENT FILTER

Through normal use, waterborne minerals and sediment become trapped in the filter. The harder your water, the greater the amount of minerals in the water, and the more often you will need to clean your filter.

**Filter Life –** Under normal conditions of continuous use, a brand new filter will operate efficiently for 1 month. It is strongly recommended to wash your filter every 30 days of use.

### To remove filter for cleaning, follow the below steps:

1. Remove both tanks from the unit and allow humidifier to operate for 30-40 minutes to consume water in the tray and in the filter. This will reduce water spillage when removing the filter.
2. Be sure the humidifier is switched OFF and the unit is disconnected from the electrical outlet.
3. Hold the front door handle and open the front door to access the filter. (see Figure 1).

## CLEANING / MAINTENANCE

4. Take off the filter support cap and take out the dirty filter (see below Filter Washing Procedure to clean your filter).

### Filter Washing Procedure:

1. The water tray should be cleaned when you clean the filter. The water tray is a convenient way to carry the filter to prevent dripping.
2. Mix 1 gallon warm tap water with 1 teaspoon concentrated antibacterial liquid dish washing soap.
3. Fully submerge filter in soap solution for 15-20 minutes.
4. Dunk filter in soap solution several times then gently press to release the soapy water. Be sure not to wring, pull or scrub filter as this will degrade the filter.
5. Run under cool tap water until there is no soap remaining. Some discoloration may still be visible, this is normal and does not affect performance.
6. Gently shake or press the filter to remove excess water.
7. The filter can be put directly into the humidifier while still damp if it is to be used right away, or allow filter to dry completely if humidifier is to be stored.

**NOTE:** Should your filter become damaged or lost, please call 1-800-253-2764 or visit [www.bionaire.com](http://www.bionaire.com) for a replacement part (HWF75P).

### To replace the cleaned filter on unit, follow the below steps:

1. Insert the cleaned filter and replace the filter support cap on top of the filter. Place the filter back onto the humidifier base. Ensure that the filter is seated correctly and can come in contact with water.
2. Close the front door properly.
3. Repeat Operating Instruction steps.

It will take about 30 minutes for the humidifier to reach maximum output.

## CLEANING AND MAINTENANCE INSTRUCTIONS

Humidifiers provide comfort by adding moisture to dry, heated indoor air. To benefit most from the humidifier and avoid product misuse, follow all instructions carefully. Please note that this is an electrical appliance and requires attention when in use.

In addition, if you do not follow the recommended care and maintenance guidelines, micro-organisms may be able to grow in the water within the water tank. You must routinely follow the cleaning procedures that follow in order to ensure proper, efficient operation of your humidifier. Proper maintenance

and cleaning is essential to the continued performance of your unit and the avoidance of algae or bacteria build-up.

### Daily Maintenance

1. Be sure the humidifier is switched OFF and the unit is disconnected from the electrical outlet.
2. Remove the tanks from the humidifier and place them in sink or tub.
3. Carry the base of the unit to the sink, remove the wick filter, place in sink, drain any remaining water. Wipe clean, and dry with a clean cloth or paper towel.
4. Drain the water from the tanks into the sink and rinse each tank thoroughly. Wipe clean, and dry with a clean cloth or paper towel.
5. Replace with cleaned filter and filter support cap, close the front door, then refill the tanks with cool tap water as instructed earlier in the Filling Instructions. Do not overfill.
6. Follow Operating Instructions.

### Weekly Maintenance

#### To Remove Scale:

1. Repeat steps 1-4 above.
2. Partially fill the base with Cleanse Clean® solution (Model S1710) as instructed on bottle, or with two 8 oz. cups of undiluted white vinegar. Leave this solution in the base for 20 minutes, while cleaning all the interior surfaces with a soft brush. Remove base scale by wiping the base with a cloth dampened with undiluted white vinegar.
3. Rinse with clean warm water to remove the cleaning solution before disinfecting the tank.

#### To Disinfect Humidifier Base Tanks:

1. Fill Humidifier Base with 2 gallons of water and 1 teaspoon of chlorine bleach.
2. Fill each tank 1/2 full with water and 1 teaspoon of chlorine bleach.
3. Let the solution stand for 20 minutes, swishing every few minutes. Wet all surfaces.
4. Carefully empty the Base and Tanks after 20 minutes, and rinse with warm water until you cannot detect any bleach smell. Dry with a clean cloth or paper towel.
5. Depending on the water hardness in your area, it may be necessary to wash the filter every month. Re-insert the cleaned filter into the filter support cap.
6. Refill the water tanks as directed with cool tap water, replace the humidifier housing, and follow the Operating Instructions to start operations.